

JENN-AIR

Use & Care Manual

Frost Free Refrigerators

MODELS JRTE176, JRTE198, JRTE218, JRTDE228

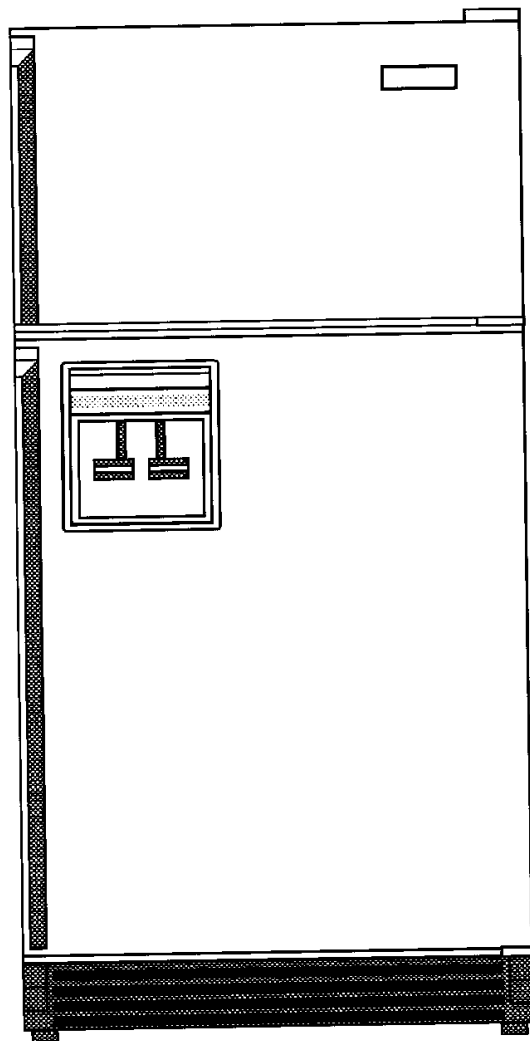

Model JRTDE228

About Your Jenn-Air Refrigerator

Your Jenn-Air frost-free refrigerator was designed, engineered, and manufactured to the highest standards of quality and performance. Since this manual explains how you can obtain the best use of your Jenn-Air, **it is essential that you follow the instructions carefully.**

Should you have any questions about using your Jenn-Air appliance, write to us. Be sure to provide the model number of your appliance.

Jenn-Air Customer Assistance
c/o Maytag Customer Service
 PO Box 2370
 Cleveland, TN 37320-2370

THE MODEL YOU HAVE SELECTED MAY NOT HAVE ALL OF THESE FEATURES SHOWN

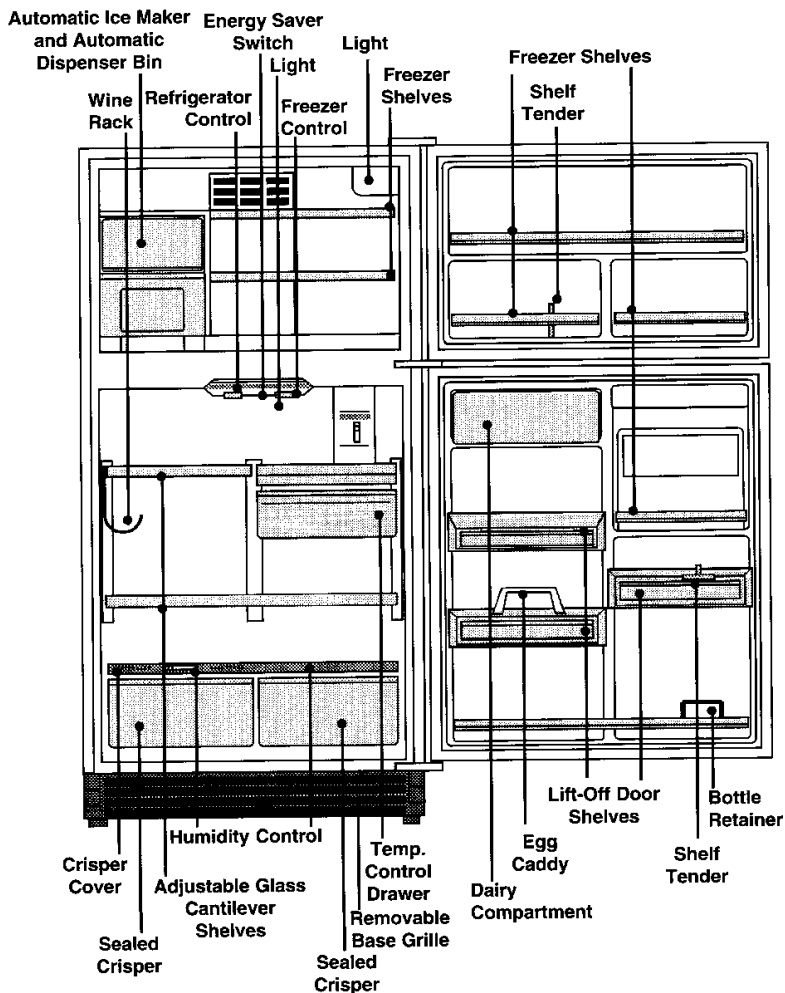

Model JRTDE228

Safety Precautions

1. Use the three-pronged plug only with a grounding receptacle to provide protection from electrical shock. This appliance must be installed in accordance with the installation and grounding instructions on page 4-5.
2. Unplug your refrigerator before cleaning condenser, replacing a light bulb, or making any repairs. Any servicing should be performed by a qualified technician.
3. In case of power failure, minimize door openings. If power failure is of long duration, protect frozen food by placing blocks of dry ice on top of the packages, or check with a local frozen foods locker plant about temporary storage. Frozen foods which have thawed completely should not be refrozen.
4. Any electric service cord that becomes frayed or damaged should be immediately repaired or replaced. Never unplug your appliance by pulling on the power cord.
5. Your refrigerator should not be operated in the presence of explosive fumes.
6. Remove the doors from any out-of-use refrigerator to prevent child entrapment and suffocation.
7. Do not place fingers or hands on the automatic ice making mechanism while the refrigerator is plugged in. This will help protect you from possible injury. It will also prevent interference with moving parts of the ejector mechanism and the heating element that releases the cubes.

Installation

Location

If you are installing your new refrigerator yourself, please follow these helpful suggestions.

1. Remove base skids.
2. Remove all exterior and interior tape carefully and retain old tape. Make a small pad of this tape to pick off any remaining tape residues. This will eliminate the need to use dangerous solvents of any kind.
3. Remove and discard the cantilever shelf packing clips located just above each shelf where they hook onto the frame. To remove the red plastic clip, wiggle it sideways and pull straight out.
4. Select a location for your new refrigerator away from any heat sources. Allow a free flow of air through the front base grille.
5. Your model should not be installed where the room temperature will go below 55° F. because it will not run frequently enough to maintain proper temperature in the freezer.

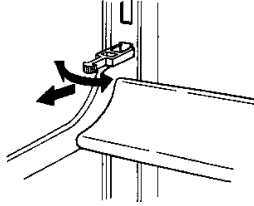

Leveling Is Important

To enhance its appearance, maintain efficient performance and for proper function of the ice maker, your refrigerator should be level. Using a carpenter's level, check your refrigerator to make sure it is level front to back and side to side. The front wheels were adjusted at the factory so the cabinet would be level. However, jarring in transit, or standing the refrigerator on an uneven floor may cause the cabinet to appear unlevel.

If leveling is necessary, remove the base grille and adjust the wheel with a screwdriver as shown.

To lock the cabinet in place, turn down one or both locking feet, located near the front wheels. Rear leveler feet are not required.

If the floor is not level and it is necessary to raise the rear of the cabinet, we suggest rolling the rear wheels on to a piece of plywood or other shim material.

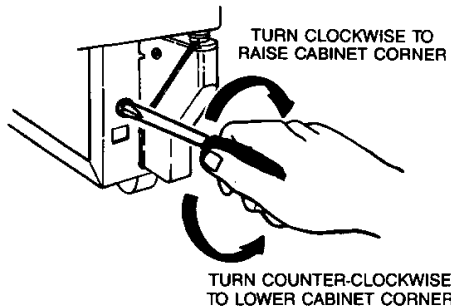

Electrical Connection and Grounding

Your refrigerator is designed to operate on a nominal 115 volt, 15 amp., 60 cycle line. There should be a separate, grounded circuit, serving this refrigerator only. **DO NOT** use an extension cord.

Your refrigerator is equipped with a three-pronged grounding plug for your protection against possible electrical shock hazards. It must be plugged into a grounding receptacle. Where a standard two prong wall receptacle is encountered, it is the personal responsibility and obligation of the customer to have it replaced with a properly grounded three-prong wall receptacle. **DO NOT**, under any circumstances, cut or remove the third (ground) prong from the power cord.

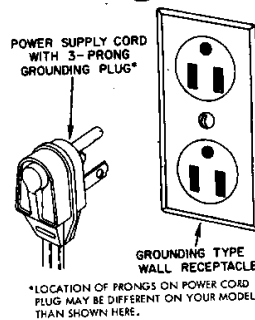

DO NOT use an adapter plug.

Changing Reversible Doors (Non-Dispenser Models Only)

Your refrigerator may have been built with the doors hinged to the right or hinged to the left. Refer to the following instructions for door reversal.

Tools Required

Phillips screwdriver
End wrench (5/16")
5/16" Socket and ratchet
Putty knife
T25-TORX driver

Changing Doors

1. Turn the fresh food control to OFF and remove all food from the interior.
2. Using a 5/16" socket and ratchet, remove the screws from the upper hinge. Carefully lift the door (including upper hinge) off of the center hinge and place it on a padded surface to prevent scratching. Avoid losing the spacer that was between the hinge and the cabinet top.
3. Unscrew the hinge pin out of the center hinge on the top of the lower door. Carefully lift the lower door off the lower hinge and place it on a padded surface. If the metal hinge pin pulls out of the lower hinge when the door is removed, pull it out of the door bottom and press it back into the hinge.
4. Using a phillips screwdriver, remove the handles from the door edges. Remove the handle end caps on Models JRTE198 and JRTE218. To attach the handles and end caps to the right side, first remove the plug buttons. Invert the handles and end caps and attach with screws. Press the plug buttons into the opposite side of the door.
5. Using a putty knife, pry the plug button cover from the metal bushing at the top of the door. Save the cover for future use.
6. Lift the upper hinge and the spacer washers from the door and install them at the opposite corner.
7. Position the plug button cover, saved from step 5, over the old hinge bushing and press it into place.
8. Pry out the 3 plastic plug buttons from the cabinet top and press them into the opposite corner.
9. With the T25 socket wrench and 5/16" socket and ratchet, remove the screws from the center hinge and spacer from the cabinet. Transfer the (2) screws from the left end of the divider bar to the right end. Install the center hinge and spacer on the left end of the divider bar the same way it was installed on the right end. Tighten both screws until they are just snug, then turn them one-half turn more.
10. Pry the plug cover from the metal bushing at the top of the lower door and press into the metal bushing on the opposite side of the door.

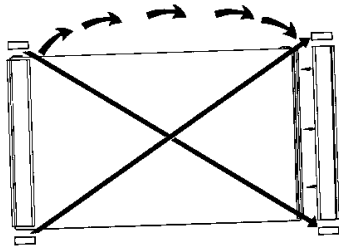

11. Remove the base grille by grasping at both ends and pulling it straight out.
12. Remove the hinge cover by squeezing both sides together.
13. Use a 5/16" socket and ratchet to remove the two screws from the bottom hinge. Save the spacer.
14. Pull the metal hinge pin from the side of the lower hinge and place it, including the spacer washer, into the top hole.
15. Pry out the two screw hole plug buttons on the bottom left side of the top door and lower door. Remove the door stops (metal plate) on the bottom of each door and install them on opposite sides. Press in the plug buttons in the holes on the right side of both doors.
16. Set the lower door on the bottom hinge, making sure the hinge pin enters the bushing in the door bottom.
17. While holding the door in a closed position, take the center hinge pin that was removed in step 3 and insert it through the left hole of the center hinge and into the bottom door bushing. Make sure the long pin goes into the bottom door and the short pin goes into the top door.
18. Set the upper door on the center hinge, making sure the hinge pin enters the door bushing. When you close the door, the gasket should hold it in place.
19. Making sure to use the same number of spacers that were originally used beneath the upper hinge, install the hinge mounting screws. Before tightening these screws, make sure the top of the door is level with the cabinet top, and the space between the door is equidistant across the entire front. Avoid over-tightening these screws. Tighten both until they are just snug, then turn them in another one-half turn.
20. Examine the door gasket all around each door, making sure no gaps are visible between the gasket and cabinet. If a gap shows, try stretching the gasket away from the door so the magnet will contact the cabinet surface.
21. To replace the base grille, line up its spring clips with the square openings in the cabinet and tap each end in until the grille locks in place. Replace hinge cover.
22. Replace all food and return the fresh food control to its usual operating position.

Operation

Setting Controls

Your new refrigerator has two controls. One for regulating the temperature in the fresh food compartment and one for the freezer. The fresh food compartment and the freezer compartment controls are located at the top front of the fresh food compartment. Turn both controls to "No. 5" to start your refrigerator.

The "No.9" freezer control setting is recommended for short term use only.

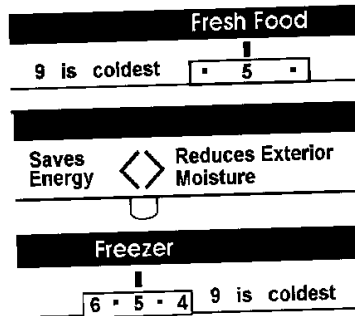

Your refrigerator may run for several hours when you first start it. This is normal and shouldn't be cause for alarm.

Changing either control will have some effect on the temperature of the other compartment.

In a day or two, you may decide that one or both compartments should be colder or warmer. If so, adjust the control(s) as instructed in the accompanying chart.

IMPORTANT: Except when starting, do not change either control more than one number at a time. Allow 24 hours for temperature to stabilize before re-setting.

<i>To start:</i>	<i>Set fresh food control on "5". Set freezer control on "5".</i>
<i>Refrigerator too WARM:</i>	<i>Turn fresh food control to next higher number.</i>
<i>Refrigerator too COLD:</i>	<i>Turn fresh food control to next lower number.</i>
<i>Freezer too WARM:</i>	<i>Turn freezer control to next higher number.</i>
<i>Freezer too COLD:</i>	<i>Turn freezer control to next lower number.</i>
<i>Refrigerator OFF:</i>	<i>Set fresh food control to OFF.</i>

Warm Cabinet Surfaces

At times, the front surfaces of your refrigerator cabinet may be warm to the touch. This is a normal function of your refrigerator. This feature prevents moisture from condensing on the outside of your refrigerator during humid weather. This condition may be noticeable when you first start your refrigerator, during hot weather, and during excessive or lengthy door openings.

Energy Saver Switch

The Energy Saver switch controls a heater designed to prevent moisture accumulation between the refrigerator and freezer door frame. During humid weather, moisture collects on objects that are cooler than the surrounding air. This condensation can be eliminated by applying a small amount of heat to the surface upon which the water accumulates.

When the Energy Saver switch is on "Saves Energy", no heat is applied to the surface. It is saving both energy and money. If humidity increases and condensation appears, turn the Energy Saver switch to "Reduces Exterior Moisture". Be sure to turn the Energy Saver switch back to "Saves Energy" as the humidity drops to save energy.

In areas of relatively high humidity, the Energy Saver Switch in the "Reduces Exterior Moisture" position will minimize any collection of moisture on the outside surface of the cabinet.

Energy Tips

For efficient energy use:

1. Be sure the refrigerator is level and ventilation around the front grille is not blocked.
2. Check door seals occasionally for leakage. Check at various places, top, bottom, and sides.
3. Check the temperature; avoid unnecessary cold settings.
4. Keep the freezer full to near capacity; less cold air is lost during door openings.
5. Let hot dishes cool before putting into refrigerator or freezer.
6. Cover liquids; if uncovered, the unit must work longer.
7. Clean refrigerator condenser coils at least twice a year.

Refrigerator Compartment Features

To maintain the natural flavor, moisture, and nutrition of fresh foods, we recommend that all dishes, trays, and containers of food be covered.

Shelves

Adjustable cantilever shelves can be positioned to suit your special needs. To remove a shelf, lift the rear straight up a fraction of an inch and pull straight out. To lock into another position, tilt the shelf with the front up. Insert hooks into desired frame openings and let the shelf settle into place. Make sure it is securely locked at the rear.

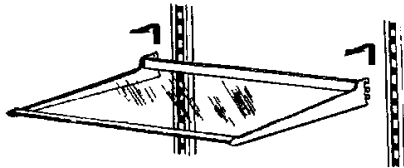

Temp Control Drawer

The Temp Control Drawer, between the top and second shelves, provides short term storage of fresh meats without freezing. This drawer will provide extra chilling only if the cantilever shelf that supports the Temp Control Drawer is in the 2nd, 3rd, or 4th shelf adjusting positions. **Keep the drawer tightly closed at all times.**

The sliding lever on the back wall, above the drawer enables you to vary the internal temperatures inside the drawer. With the lever set at the "Cold" position, the temperature inside the drawer will be cooler and you can store most good quality meats several days.

All meats or poultry should be stored in their original store wrappings or in plastic bags to reduce the evaporation of moisture from them.

To remove the Temp Control Drawer, pull it out until it stops. Then apply a little more pressure and pull completely out.

Sealed Crispers

The Sealed Crispers are ideal for storing vegetables and fruit. Keep your crispers tightly closed to insure freshness. Storing leafy vegetables, such as celery and lettuce in plastic bags, reduces moisture evaporation.

The crispers slide out for easy access to foods stored within. They are completely removable for cleaning (hand wash only) or for use elsewhere in your kitchen.

The crisper cover also serves as a refrigerator storage shelf. Below are directions for removing the crisper cover for cleaning.

Model JRTE176: Lift the front edge and pull straight out. To replace the cover, set rear bars on supports and push back until the front can be lowered into place. If the crisper shelf is not level, adjust the support leg (see below).

Models JRTE198, JRTE218, JRTDE228: Push up on the glass cover from underneath and carefully remove.

Leveling Crisper Shelf (Model JRTE176 Only)

If the crisper shelf is not level, adjust the support leg as shown.

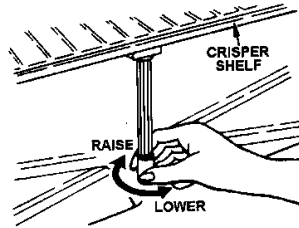

Humidity Control (Most Models)

The humidity control levers are located on the shelf above the crisper drawers. The slide control should generally be set at the "Low" setting for fruits and the "High" setting for vegetables.

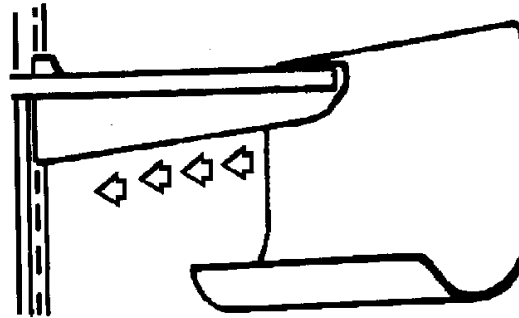

Wine Rack

To use your wine rack fit it along either side of any refrigerator shelf and lay the wine bottle on the rack.

Occasionally, you may notice water droplets on the back wall. This is normal. Defrost water is used to maintain humidity level and helps keep food fresh longer. Excess water drains into the defrost pan beneath the cabinet and evaporates.

Door Features

Egg Caddy

Your model has an egg caddy that fits securely on a door shelf. This egg caddy can be removed and carried to your working area.

Magnetic Door Gaskets

Door gaskets are magnetized to insure an air tight seal all around. These gaskets cling to the cabinet front, once the doors are closed to within their magnetic range.

Lift-Off Door Shelves (Most Models)

Lift-off door shelves may be easily adjusted to another position on the door. Lift the shelf straight up until it clears the retainers on the door liner and pull straight out. Reverse this procedure when replacing a shelf.

Bottle Retainer

Some models have a bottle retainer located on the lower refrigerator door shelf. It prevents tall bottles from falling out when the door is opened or closed. The bottle retainer can be adjusted to any position on the shelf by sliding sideways.

Shelf Tender

All models have a Shelf Tender located on one of the refrigerator door shelves. It provides upright storage for packages or bottles. The Shelf Tender can be adjusted to any position on the shelf by sliding sideways.

Freezer

Compartment Features

To maintain the natural flavor, moisture, and nutrition of frozen foods, and to prevent freezer burn, we recommend that all foods be wrapped or sealed properly.

Freezer Shelf (Model JRTE176)

The freezer shelf can be removed by (1) lifting the right end up and out of clip supports approximately six inches and (2) pulling the left end bars out of the sockets in the left side wall. Reverse the removal procedure to replace the shelf, making sure the right end bars are pressed completely into the clip support.

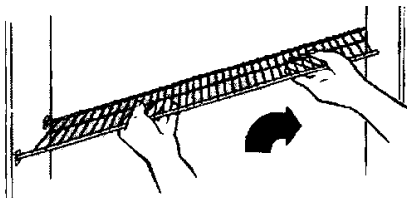

Freezer Shelf (Model JRTDE228)

The freezer shelf can be removed by (1) lifting the right end up approximately 1" (2) push the shelf to the right as far as it will go into the sockets (3) lift the left end up approximately 3" and (4) pull the right end bars out of the socket in the side wall.

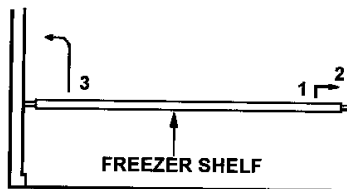

Expandable Freezer Shelf (Models JRTE198/JRTE218)

Some models have an expandable-width freezer shelf which adjusts sideways to open up a full-height space for tall packages, such as pizza. The right side of the shelf is supported by a wide leg that slides sideways in channels on the underside of the shelf. The shelf can also adjust to two heights. This requires removing the shelf from the freezer, sliding the leg out of the channels, re-inserting it in the alternate height position and returning the shelf to the freezer, hanging on the alternative hooks. (Usually, the right support section will be expanded fully to the right wall surface, unless vertical storage of narrow packages is desired.)

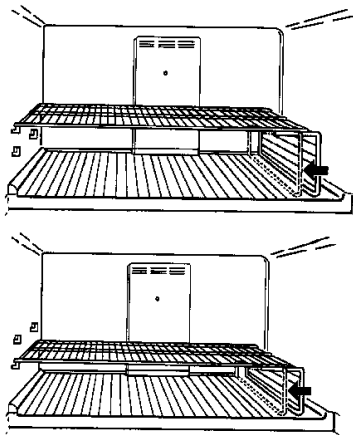

Tilt Out Freezer Basket (Models JRTE198/JRTE218)

Some models have a tilt out basket on the lower shelf of the freezer door. Tilting the basket forward by its upper edge provides easy access to packages. A slight push upward will tilt the basket back to its proper stored position.

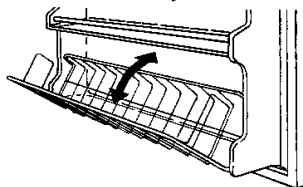

Ice Cube Trays (Non-dispenser Models)

Your refrigerator comes equipped with ice cube trays and a storage bin. To release frozen cubes, hold the trays upside down over the storage bin and twist both ends.

Optional Automatic Ice Maker

Some models are designed so an Automatic Ice Maker can be easily installed whenever you want it. Order the ice maker kit number shown on the label on the cabinet back. The kit contains installation instructions, water connection instructions and other information concerning the ice maker operation.

Automatic Ice Maker

The water inlet tubing assembly required to complete the water connection to the water valve is located in the crisper drawer in a bag. Connect the ice maker to the water supply as instructed in the separate instructions, furnished with the refrigerator.

The automatic ice maker is designed to furnish a continual supply of ice cubes. The amount of ice produced depends on the temperature in the freezer section of your refrigerator. The colder the freezer section, the more ice is produced. We suggest you start with your refrigerator and freezer controls at their mid settings. In most cases, this is satisfactory. If the door to the refrigerator or freezer is opened frequently or temperatures in the kitchen are abnormally high, a colder setting may be necessary.

After your model has been installed and the water supply connected to the ice maker, it may take 8 to 12 hours before the ice maker furnishes any usable ice cubes. The first one or two harvests will probably contain undersized and irregular cubes because of air in the supply line. The initial harvest may also contain impurities from the new water supply piping. Therefore, all cubes from the first two or three harvests should be discarded.

Under certain rare circumstances, ice cubes may be discolored, usually appearing with a green-bluish hue. The cause of this unusual discoloration is apparently a combination of factors such as certain characteristics of local waters, household plumbing and the accumulation of copper salts in an inactive water supply line which feeds the ice maker. Continued consumption of such discolored ice cubes may be injurious to health. If such discoloration is observed, discard the ice cubes and contact the dealer from whom the ice maker or refrigerator was purchased.

Ice cubes that have been in the ice storage for a considerable length of time may pick up off-flavor taste, stick together, and gradually become smaller. We suggest that these cubes be thrown away. We also suggest using an open box of baking soda in the refrigerator for food odor absorption.

Certain sounds may accompany the various cycles of the ice maker. Examples are: (1) The motor may have a slight hum, (2) the cubes will rattle as they fall into an empty storage bin, and (3) the water valve may click or "buzz" occasionally. All of these sounds are normal and should be ignored.

Note: When dispensing ice cubes, it is important that you use only the ice supplied by this ice maker. Ice from any other source could cause an ice jam. If this happens, remove and discard all ice from the storage bin and any ice lodged in the ice chute.

Starting or Stopping Your Ice Maker

Your automatic ice maker is located near the top of the freezer compartment behind the Ice Access Panel. To gain access to the ice making mechanism, lift the Ice Access Panel.

The ice maker has a wire sensor arm that is connected to a shut-off switch. This arm stops the mechanism when the ice cube storage bin is full, and restarts it after several ice cubes have been used. You can use the stop arm to stop all production of ice at any time. All you need to do is raise the arm into the OFF position.

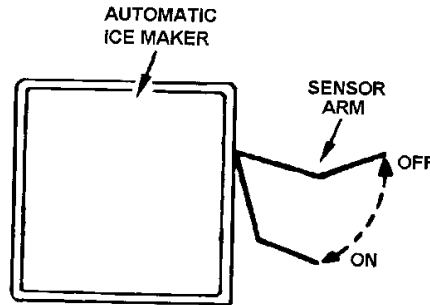

The ice maker should be turned off (arm up) when:

1. Ice storage bin is to be removed for extended period of time.
2. Refrigerator is not to be used for a considerable time, such as vacations. Also, turn off the water supply to the ice maker in this instance, if practical.
3. Water supply is to be shut-off for several hours.

How the Ice Maker Works

Water fills the empty cube mold (Fig. 1) when the freezer compartment has cooled to freezing temperature. Cold air is forced directly over mold.

When frozen, the cubes are rotated up and out of the mold (Fig. 2). The sweeper arm ejects them into the ice storage bin below.

The sensor arm (Fig. 3) senses when the bin is full and signals the ice maker to stop ejecting more cubes.

However, the mold has been refilled and cubes frozen so the new supply is ready when needed. As soon as ice is removed from the bin, the sensor arm signals that more is needed. The ice maker resumes operation by ejecting ready-and-waiting frozen cubes.

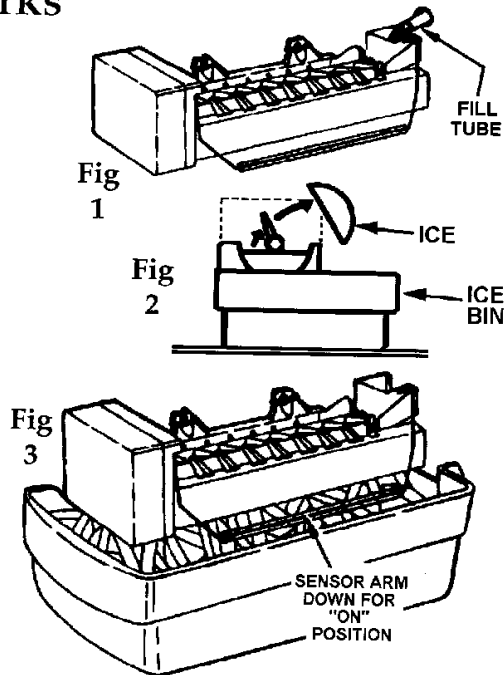

Removing and Replacing the Automatic Ice Cube Dispenser Bin

Lift the front of the Automatic Dispenser bin and pull it straight out. Wash the bin occasionally in mild soap and lukewarm water. To replace the bin, push it all the way back until the bottom of the bin is behind the raised edge at the front of the shelf it rests upon. Make sure the tabs, at the back of the bin, that turn the spiral auger are positioned between the prongs from the auger motor.

Operating Your Automatic Ice Cube Dispenser

Prevent ice cubes from missing your glass by holding it as high as possible (just below the ice chute). Press the glass against the padded lever at the left side of the fountain. To stop dispensing ice, release pressure just enough to stop the dispenser motor and leave the glass in place to hold the door open until ice stops falling. With a little practice, you will learn to anticipate when to release pressure to prevent an unwanted dispense of ice, which occurs each one and one half seconds.

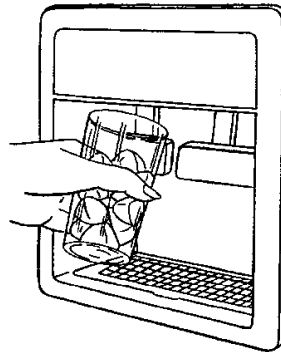

After installation, it may take 1 to 2 days to fill the Automatic Dispenser bin with ice cubes.

Operating Your Water Dispenser

To dispense water, press a container against the padded lever at the right side of the fountain. To stop the water flow, release pressure. To minimize splashing, hold the container as high as possible.



When you first operate your dispenser or after reconnecting water to your refrigerator, air will escape from the dispenser for a few minutes before water begins to flow. Draw 10 glasses of water and empty them in the kitchen sink. This will insure complete filling of the reservoir with fresh water.

Spill Tray

Do not discard water into the grille at the bottom of the fountain. This is a spill area, not a drain. Normal spills will be evaporated in the recessed area below the spill shelf grille. Excessive spills should be removed with an absorbent sponge or cloth. The spill area should be cleaned occasionally.

Fountain Light

The push button light switch is located behind the panel at the top and on the right side of your fountain. For replacement, use a 120v, 7 watt bulb.

Child Proof Lock

A child proof lock is located behind the panel at the top and on the left side of the dispenser. This push button switch will turn your ice and water dispensers on or off.

Cleaning

It is recommended that you disconnect the power cord before cleaning.

Your refrigerator can be rolled out for cleaning. Turn the levelers, at each front corner of the cabinet, **counterclockwise** until they turn freely. Then pull the cabinet straight out. If you have an installed Automatic Ice Maker, we recommend that you turn off the water supply before moving the cabinet.

After cleaning behind your refrigerator, push it back and turn the levelers **clockwise** until they touch the floor and lock the cabinet in place.

Outside

Use mild soap and water, **DO NOT** use scouring powders, automobile wax, or furniture polish. Rinse with clear water.

Door gaskets may be cleaned with soap and water, a baking soda solution, or mild scouring power.

Inside

Clean both compartments and inner door panels with mild soap and water. Do not use an abrasive powder, solvent, polish cleaner or undiluted detergent.

You may notice a slight discoloration appearing at the top and near the center of the back wall of the fresh food compartment. This is no cause for alarm, but it should be cleaned off periodically.

When cleaning a glass cantilever shelf, you can remove it and submerge the entire assembly in warm water. Never use hot water. **Always allow glass to warm up to room temperature before immersing in warm water.**

Defrost Pan

Defrost water drains into a shallow pan beneath the cabinet and evaporates. During periods of high humidity, water could remain in the pan. This pan should be cleaned once a month with a strong solution of soap and water.

To remove defrost pan, grasp the base grille on both ends and pull it straight out. Slide the pan out from underneath the cabinet.

To replace the defrost pan, position the side flanges to fit over the slide rails and push it in until it stops.

To replace the base grille, line up the spring clips on the base grille with the square openings on the refrigerator. Tap each end in until the base grille locks in place.

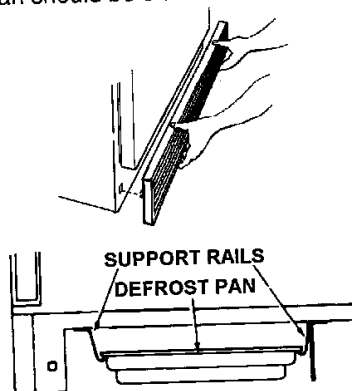

Condenser

To allow your refrigerator to run more efficiently, the base grille and the area around the condenser should be cleaned at least one per year. The area around the condenser can be cleaned whenever the refrigerator is moved during routine house-cleaning. Unplug the refrigerator and move it away from the wall. Vacuum the condenser and base grille area and the area where the cabinet normally sits. Plug in the refrigerator after cleaning.

To clean the base grille, grasp both ends and pull straight out. After cleaning, replace the base grille.

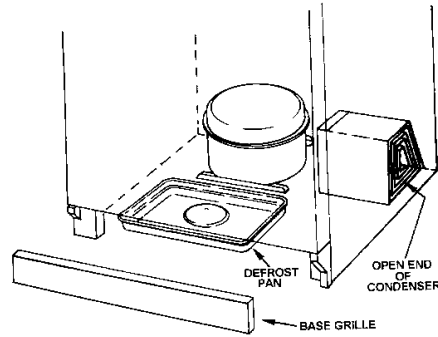

Other Hints On Caring For Your Refrigerator

Replacing Light Bulbs

It is recommended that you disconnect the power cord before replacing light bulbs.

Always use a 40 watt, standard base, appliance type bulb when replacing a light.

For models JRTE198, JRTE218 & JRTDE228: Replace freezer bulb by: (1) using two hands spread each side of the light cover outward and pull to the front; (2) unscrew and replace bulb; (3) push right hand side of light cover toward back of freezer engaging tab in slot. Then push left side toward back engaging left tab in slot.

Going On Vacation

If you will be gone for a month or less, leave the control knob at its usual setting.

During longer absences, (a) remove all food, (b) disconnect from electrical outlet, (c) clean the refrigerator thoroughly, including defrost pan, (d) leave doors open to prevent odor formation.

Before You Call For Service

Problems? Save yourself the nuisance of unnecessary service calls; check these first:

Refrigerator runs too frequently.

- Frequent running provides more stable temperatures.
- Too many door openings.
- Prolonged door openings.

Refrigerator runs too long.

- Under normal conditions, due to larger size and colder temperatures, modern refrigerators run a greater percentage of the time.
- Prolonged or frequent door openings.
- Condenser needs cleaning.
- Poor air circulation around condenser.

Refrigerator won't run.

- Temperature control turned to OFF.
- Power cord not plugged in.
- No power at electrical outlet.
- House fuse blown or circuit breaker tripped.

Cabinet vibrates.

- Cabinet not level.
- Weak floor.

Warm air from cabinet bottom.

- Normal air flow for condenser circulation.

Front cabinet surface warm to touch.

- Special design to prevent condensation during periods of high humidity.

Moisture on outside surface.

- Hot, humid weather increases condensation. When humidity drops, condensation disappears. During hot humid weather, turn the Energy Saver switch to "Reduces Exterior Moisture".

Sizzling sound in freezer.

- Normal sound caused by defrost water dripping on defrost mechanism.

Water on floor under cabinet.

- Defrost pan missing or not positioned correctly.

Water in fresh food compartment bottom.

- Cabinet not level.
- Drain tube plugged.

Noisy operation.

- Fan noise perfectly normal in frost-free refrigerators. You may not be used to this if previous model was manual defrost.
- Cabinet not level.
- Weak floor.
- Defrost pan not positioned correctly.

Odor in cabinet.

- Defrost pan needs cleaning.
- Food left uncovered.
- Interior needs cleaning.

Foods dry out (Fresh or Frozen).

- Packages not wrapped or sealed properly.
- Crisper not tightly closed.

Fresh food compartment too cold.

- Refrigerator control set too cold.

Fresh food compartment too warm.

- Refrigerator control set too warm.
- Freezer control set at coldest position.
- Prolonged door openings.

Freezer compartment too warm.

- Freezer control set too warm.
- Prolonged door openings.

Ice cubes evaporate.

- Cold air moving over ice cubes causes shrinkage.

Automatic ice maker not operating

- Stop arm in OFF position.
- Water supply turned off.
- Water pressure too low.
- Freezer too warm.

Ice Dispenser not operating.

- Ice jam in the dispenser.
- Ice maker not operating.

Water Dispenser not operating.

- Water supply turned off.
- Water pressure too low.

Cabinet light not working.

- Bulb burned out.
- No power at outlet.

Water appears on back wall of fresh food compartment

- Normal function during defrost cycle. Water flows to the bottom of the compartment and drains into the defrost pan.

If You Need Service

- Call the dealer from whom your appliance was purchased or the authorized Jenn-Air Service Contractor listed in the Yellow Pages. Your Jenn-Air Contractor can provide better and faster service if you can accurately describe problems and give model and serial number of the appliance. Be sure to retain proof of purchase to verify warranty status. Refer to WARRANTY for further information of owner's responsibilities for warranty service.
- If the dealer or service company cannot resolve the problem, write to Jenn-Air Customer Assistance, c/o Maytag Customer Service, PO Box 2370, Cleveland, TN 37320-2370, 615-559-3646.
- Use and care manuals, service manuals, and parts catalogs are available from Jenn-Air Customer Assistance, c/o Maytag Customer Service for a nominal charge.

All specifications subject to change by manufacturer without notice.

Important Information

Model Number _____ Serial Number _____

Bill of Material Number _____

Date Purchased _____

JENN-AIR DEALER FROM WHOM PURCHASED

Address _____

City _____

Phone _____

AUTHORIZED SERVICE CONTRACTOR

Address _____

City _____

Phone _____

IMPORTANT: Retain proof of purchase documents for warranty service